

HAND RAIL

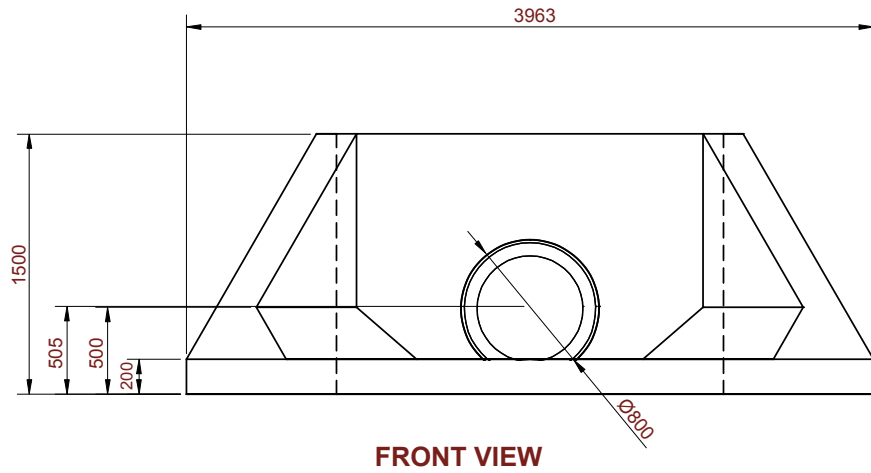

FRONT VIEW

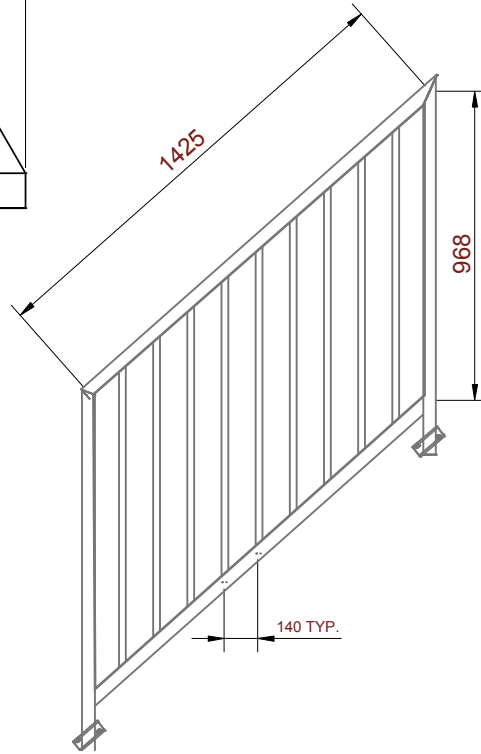

SIDE HAND RAIL TYPICAL

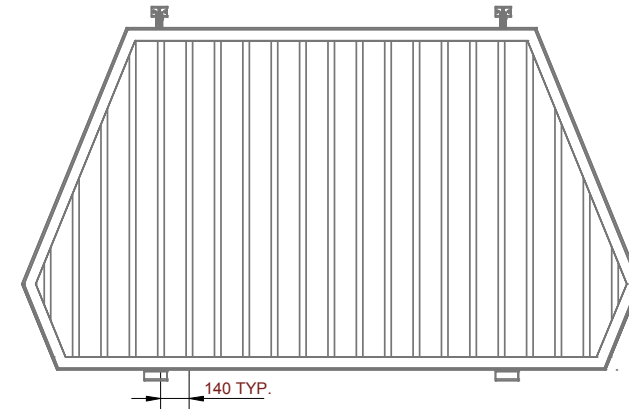

INFLOW GRATE

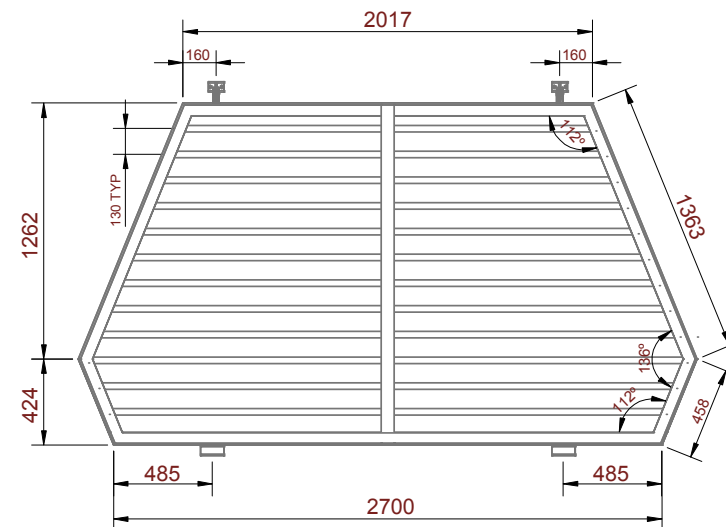

OUTFLOW GRATE

TYPICAL GRATE

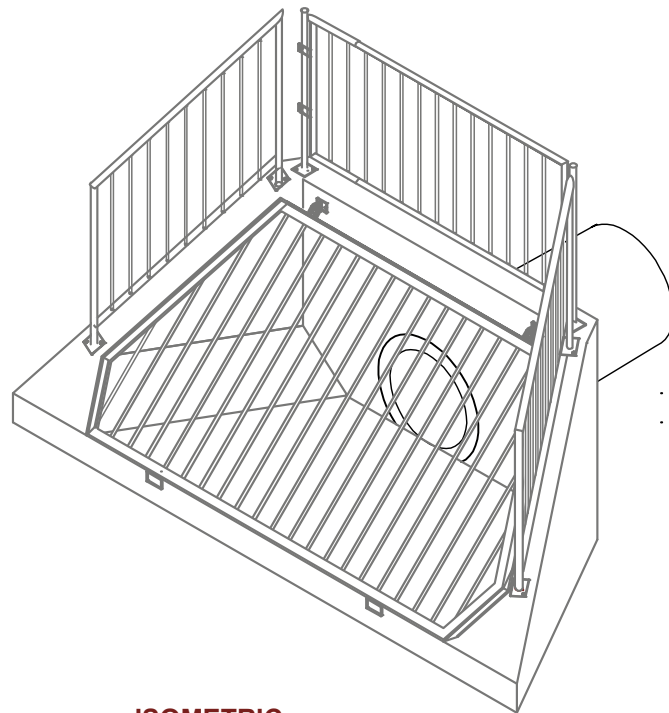

ISOMETRIC

SHAW SUPPLIED ITEMS	
3	STAINLESS STEEL "L" BRACKETS
6	190mm (3/4") STAINLESS DROP-IN ANCHORS
6	190mm (3/4") x 380mm (1 1/2") BOLTS
6	190mm (3/4") WASHERS

NOTES

- GENERAL**
- FOR HANDLING, STORAGE, TRANSPORTATION AND ERECTION PROCEDURES PLEASE REFER TO "HEADWALL INSTALLATION GUIDE" AND "DAYTON/RICHMOND GUIDELINES FOR HANDLING CONCRETE PIPE AND UTILITY PRODUCTS".
 - WEIGHT = 4700 kg
 - TOLERANCE FOR STRUCTURAL ELEMENTS, MATERIALS & CONSTRUCTION CONFORM TO CAN/CSA A23.4 "PRECAST CONCRETE" CLAUSE 10.
 - PRECAST HEADWALL MUST BE FASTENED TO REINFORCED CONCRETE PIPE WITH SHAW SUPPLIED HARDWARE (SEE HEADWALL INSTALLATION GUIDE).
- GEOTECHNICAL**
- GEOTECHNICAL ENGINEER TO PROVIDE ON-SITE INSPECTION FOR PLACEMENT AND COMPACTION OF BACKFILL.
- DESIGN**
- THIS STRUCTURE HAS BEEN DESIGNED IN ACCORDANCE WITH CAN/CSA S6.06 UNDER THE FOLLOWING DESIGN PARAMETERS:
 - DESIGN LIVE LOAD = CL-625
 - DESIGN DEAD LOAD = 2H:1V EARTH FILL TOP SLOPE.
 - CONCRETE UNIT WEIGHT = 24.0 kN/m³
 - SOL/BACKFILL UNITWEIGHT = 22.0 kN/m³
- REINFORCEMENT**
- ALL REINFORCING STEEL SHALL BE GRADE 400 AND CONFORM TO CAN/CSA G30.18 (LATEST EDITION).
 - ALL WELDED WIRE MESH SHALL HAVE A F_y = 485 MPA AND CONFORM TO CAN/CSA G30.14 AND G30.15 (LATEST EDITION).
 - ALL REINFORCING SHALL BE DETAILED, FABRICATED, PLACED AND SUPPORTED IN ACCORDANCE WITH CAN/CSA A23.4 (LATEST EDITION).
 - THE CONCRETE COVER OVER PRINCIPAL REINFORCING SHALL BE 50mm ± 10mm AS REQUIRED BY ENVIRONMENTAL EXPOSURE 8.11.2.2 (a) IN CAN/CSA S6.06.
- CONCRETE**
- CONCRETE MIX DESIGNS SHALL CONFORM TO REQUIREMENTS:
 - CONCRETE STRENGTH = 28 MPA AT TIME OF STRIPPING
 - DESIGN CONCRETE STRENGTH OF 45 MPA AT 28 DAYS OR TIME OF SHIPPING
 - 5% TO 7% AIR ENTRAINMENT
 - GLEN HOLME AGGREGATE SHALL BE USED WITH A NOMINAL AGGREGATE SIZE OF 13mm
 - CONCRETE CURING SHALL BE IN CONFORMANCE WITH CAN/CSA A23.1 (LATEST EDITION).
 - SHAW CONCRETE BATCH No. SHALL BE 406.
- ITEMS INCLUDED:**
- HWHANDSM
 - HWG1500H OR HWG1500V

REV NO.	REASON	DATE



DRAWING NO.

DRAWING NO.
STANDARD HEADWALL
1500 X 1500 C/W 600 PIPE

DRAWING NO.
STANDARD LAYOUT
HAND RAILS
INFLOW / OUTFLOW GRATES

CONTRACTOR
XXXXXXXXXX

DATE
22 JANUARY 2008

SCALE
AS NOTED

DRAWN
N. DIMOCK

CHECKED
R. MacDOW