



T-WALL



The T-WALL, Retaining Wall System is a gravity structure constructed of individual precast T-WALL, units. Each T-WALL, unit consists of a front face panel and a stem, which extends back into and engages the soil. The standard height for the face panel and stem is 750mm. The face panel typically has a width of 1500mm. Stem lengths vary and are selected on the basis of wall height and stability.



www.shawpipe.com

T - WALL



The T-WALL, Retaining Wall System is a gravity structure constructed of individual precast T-WALL, units. Each T-WALL; unit consists of a front face panel and a stem, which extends back into and engages the soil. The standard height for the face panel and stem is 750mm. The face panel typically has a width of 1500mm. Stem lengths vary and are selected on the basis of wall height and stability.

The design for each T-WALL, structure is carried out by Professional Engineers as part of the wall supply service. The wall structure is checked to ensure adequate safety factors for overturning, pullout and sliding. The bearing pressure along the underside of the wall is calculated using the Meyerhof method and checked against the allowable bearing capacity. Stamped shop drawings are available for each project

T-Wall

The modular nature of the **T-WALL**, unit provides flexibility for wall layout and allows on-site modifications when unexpected conditions such as rock outcrops or existing services are encountered. **SHAW PIPE** provides the joint materials, filter fabric, special lifting devices and all other materials required for complete on-site wall erection.

SHAW PIPE offers one on one consultation for layout and design of **T-WALL**, projects. We will assist on the project from the conceptual stage, through to final design and on-site installation.

APPLICATIONS

T-WALL, provides cost effective solutions to a number of site conditions commonly encountered in commercial, industrial and public works. Typical applications include:

- Highways, roads, and parking lots
- Bridge abutments and wingwalls
- Site development
- Bank stabilization
- Retaining walls

T-WALL® UNIT WEIGHTS	
STEM LENGTH (mm)	WEIGHT (kg)
1219	726
1829	839
2438	953
3048	1066
3658	1179
4267	1315
4877	1429
5486	1542
6096	1656

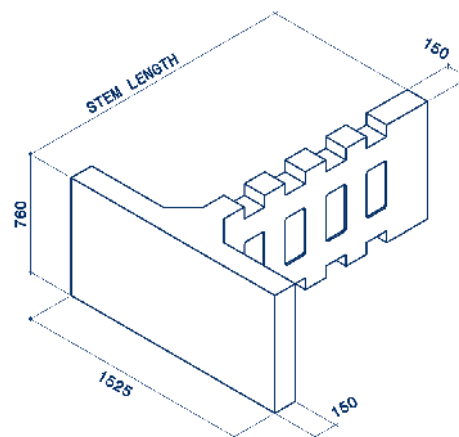

Construction Procedures Retaining Wall Structures T-Wall

All the components required for complete on-site erection of a T-WALL, structure are supplied and delivered to site by SHAW PIPE. A SHAW PIPE representative is available at the start of wall erection to provide hands on technical assistance. An overview of the straightforward construction steps for a T-WALL, structure follows:

FOUNDATION PREPARATION: The foundation is prepared by grading level and proof rolling the area where the T-WALL, units are to be placed. Unsuitable materials below subgrade are removed and replaced with compacted granular backfill.

LEVELING PAD: A nonstructural, non-reinforced concrete leveling pad is placed along the line of the wall face to provide a working platform for placement of the T-WALL, units. A chalk line is established on the leveling pad to mark the front face of the wall.

FIRST T-WALL, COURSE: Starting at a fixed point such as a corner of the wall or an existing structure the first course of units is set using the chalk line on the leveling pad to line up the front faces.

BACKFILLING: Prior to initial backfilling a 300mm wide filter fabric is cut into lengths equal to the height of the wall at each vertical joint. These strips are placed across the vertical joints between the units to prevent migration of the backfill material through the joints. The Backfill material is dumped directly on the tops of the stems to fill both sides equally and prevent lateral movement of the unit. The backfill is compacted in 300mm lifts.

SUBSEQUENT T-WALL, COURSES: Joint material is placed in the horizontal joints between the units at the front face to prevent concrete to concrete contact and to act as a gasket against loss of fines through these joints. Precast shear keys are placed in the blockouts in the top of the stems to provide an alignment guide and prevent movement of the units during backfilling. Backfilling and compaction of each lift of T-WALL, units is completed before the next course is started.

T-Wall Advantages:

A T-WALL, STRUCTURE WILL PROVIDE:

A HIGH QUALITY PRODUCT: Fabrication of the T-WALL, units by experienced crews in a controlled environment ensures a high quality product. Units are cast in the plant under comprehensive quality control eliminating the drawbacks imposed by weather and site conditions.

ECONOMY: T-WALL, structures are cost competitive with traditional cast in place retaining walls.

QUICK AND EASY ON-SITE INSTALLATION: The installation of a T-WALL, structure involves preparation of the site, placement and backfilling of wall units. Depending on project size, preparation of the site may be completed in a matter of hours. Placement of wall units can be carried out by on site equipment such as a large excavator and is a straight forward and rapid operation.

SCHEDULE: Precast fabrication of T-WALL, reduces the amount of work on-site and possible impact of weather on project schedules. The wall units can be installed, backfilled and placed into service immediately upon delivery to the site. T-WALL, units can be preordered to allow projects to proceed on-site in early spring.

REDUCED WATER CONTROL COSTS: On projects where the work site involves a water course, a precast structure eliminates the need to maintain a dry site for the entire duration of the project reducing water control requirements and costs.

DURABILITY: Precast concrete products have all the durability advantages of high quality concrete, without the concern of breakdown of protective coatings, corrosion or other problems associated with other materials.

EASE OF INSPECTION: The Purchaser has the option to inspect the T-WALL, units at the plant prior to delivery. With cast in place structures, deficiencies such as low concrete strength represent a costly problem as the product is already in place

VERTICAL T-WALLS – LEVEL EMBANKMENT

Course	Distance from top of wall (mm)	WALL HEIGHT (mm)								
		2286	3048	3810	4572	5334	6096	6858	7620	8382
		STEM LENGTH (mm)								
1	762	1219	1219	1219	1219	1219	1219	1219	1219	1219
2	1524	1219	1219	1219	1219	1219	1219	1219	1219	1219
3	2286	1829	1829	1829	1829	1829	1829	1829	1829	1829
4	3048		1829	1829	1829	1829	1829	1829	1829	1829
5	3810			2438	2438	2438	2438	2438	2438	2438
6	4572				3048	3048	3048	3048	3048	3048
7	5334					3048	3048	3048	3048	3048
8	6096						3658	3658	3658	3658
9	6858							4267	3658	3658
10	7620								4267	4267
11	8382									4877

VERTICAL T-WALLS – SLOPED EMBANKMENT

Course	Distance from top of wall (mm)	WALL HEIGHT (mm)								
		2286	3048	3810	4572	5334	6096	6858	7620	8382
		STEM LENGTH (mm)								
1	762	1219	1219	1219	1219	1219	1219	1219	1219	1219
2	1524	1219	1219	1219	1219	1219	1219	1219	1219	1219
3	2286	1829	1829	1829	1829	1829	1829	1829	1829	1829
4	3048		2438	2438	2438	2438	2438	2438	2438	2438
5	3810			3048	3048	2438	2438	2438	2438	2438
6	4572				3658	3048	3048	3048	3048	3048
7	5334					3658	3658	3658	3658	3658
8	6096						4267	4267	4267	4267
9	6858							4877	4877	4877
10	7620								5486	5486
11	8382									6096